

Light – Reflection and Refraction

1 Mark Questions

1. What is the focal length of a plane mirror?
2. A ray of light is incident on a plane mirror making an angle 60° with the mirror surface. What will be the angle of reflection?
3. What is the power of a plane mirror?
4. Show that the parallel rays incident on a convex mirror appear to diverge from its focus.
5. What happens to a ray of light that passes through the centre of curvature of a concave mirror?
6. For a spherical mirror $m < 1$. Will the image size be smaller or larger than the object size?
7. Why is concave mirror used as a shaving mirror?
8. No matter how far you stand from a mirror, your image appears erect. What is the nature of the mirror?
9. The refractive index of medium A is 1.63 and that of another medium B is 1.36. In which medium, the speed of light is more?
10. Complete the ray diagram to show the principle focus of the given spherical mirror. Name the mirror.

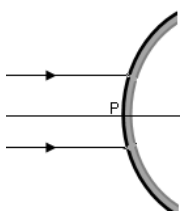

11. Show, by ray diagram, the refraction of a ray of light as it travels from air to water.
12. How do we classify a material as an optically denser or rarer medium?
13. If a ray of light goes from a rarer medium to a denser medium, will it bend towards the normal or away from it?
14. Why does the floor of swimming pool appear closer than its actual depth?
15. Define 1 dioptre power of a lens.
16. How does the sign of magnification indicate the nature of image?
17. What is the cause of refraction of light?
18. What is the relation between the refractive index and speed of light in the medium?
19. Which of the two has a greater power: a lens of short focal length or a lens of large focal length?
20. How does the focal length of convex lens changes if red light is used instead of blue light?

2 Mark Questions

1. If you are driving a car, what type of mirror would you prefer to use for observing traffic at your back and why?
2. Magnification of a plane mirror is $m = +1$. What does this indicate?
3. State four characteristics of image formed by a plane mirror.
4. State the basic laws of reflection.
5. Why is the word **AMBULANCE** written as **AMBULANCE** on the vehicles used to carry sick people?

6. How will you differentiate between a plane mirror, a concave mirror and a convex mirror without touching it?
7. We have to form an erect image of an object placed in front of a concave mirror of focal length 15 cm. Draw the ray diagram.
8. Show by the use of a ray diagram, that a concave lens always diverges light.
9. What is the difference between real and virtual image? Give one example of each type of image.
10. Why does a pencil kept in a partially water- filled glass beaker look bent?
11. State two uses of concave mirrors.
12. Optical density of a substance is different from its mass density. Support this statement by giving one example.
13. List two uses of convex mirrors.
14. Draw diagrams to show pole, centre of curvature, principle axis and aperture of a concave mirror.
15. Distinguish between a convex and a concave lens.

Numerical

1. An object is placed at a distance of 10 cm from a convex mirror of focal length 15 cm. Find the position and nature of the image.
2. An object of height 5 cm is held 25 cm away from a converging lens of focal length 10 cm. Draw a ray diagram and find the position, size and the nature of the image.
3. A concave mirror produces three times magnified real image of an object placed at 10 cm in front of it. Where is the image located?
4. An object 0.05 m high is placed at a distance of 0.5 m from a concave mirror of radius 0.2 m. Find the position, nature and size of the image formed.
5. A real image of $\frac{1}{5}$ th the size of the object is formed at a distance of 18 cm from a mirror, what is the nature of the mirror and calculate its focal length.
6. A converging mirror forms a real image of height 4 cm of an object of height 1 cm placed 20 cm away from the mirror. Calculate the image distance and the focal length of the mirror.
7. An object is kept at 10 cm distance from a concave lens. Calculate the image distance if focal length of the lens is 2 cm.
8. A lens has a power -2D. Identify the type of lens. What will be the focal length of the lens?
9. A concave lens has focal length of 20 cm. At what distance from the lens should a 5 cm tall object be placed so that it forms an image at 15 cm from the lens? Also calculate the size of the image formed.
10. A 50 cm tall object is placed on the principle axis of a convex lens. Its 20 cm tall image is formed on the screen placed at a distance of 10 cm from the lens. Calculate the focal length of the lens.

The Human eye and Colourful World

1 Mark Questions

1. What is the main function of ciliary muscles?
2. What do you mean by 'near point' and 'far point' of eye?
3. What is the function of pupil?
4. What type of image is formed by the eye lens on retina?
5. On what factor does the variation caused in the size of pupil by iris depend?
6. Who was the first scientist to use a glass prism to obtain the spectrum of sunlight?
7. Where do you see (i) concave lens and (ii) convex lens in bi-focal lens?
8. A person cannot see beyond 1.2m distinctly. What is the nature of the lens used to restore proper vision?
9. Name a natural phenomenon which is caused by the dispersion of sunlight in the sky?
10. Which of the two is scattered more easily: light of shorter wavelength or light of longer wavelength?
11. Which colour light is produced due to the scattering of sunlight by very small sized constituent particles of the atmosphere?
12. Which colour light is produced due to the scattering of sunlight by very large size constituent particles of the atmosphere?
13. Name two natural phenomena based on refraction of light.
14. What is the cause of dispersion of light?
15. The diagram shows white light being dispersed by a prism. What colour would you see at X and Y?

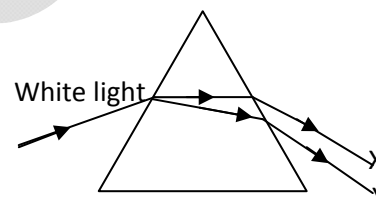

2 Mark Questions

1. The distance between the eye lens and retina is fixed. Then, how is the eye lens said to have adjustable focal length?
2. What are the two main causes of Myopia?
3. What are the two main causes of hypermetropia?
4. What is Tyndall effect?
5. A student sitting in the last row of the class is not able to read clearly the writing on the blackboard:
 - a. Name the type of defect of vision he is suffering from.
 - b. How can this defect be corrected?

3 Mark Questions

1. With the help of a diagram explain the atmospheric refraction of sun's rays causing apparent early sunrise and late sunset.
2. With the help of diagram, explain the formation of a rainbow by a raindrop.

3. What is presbyopia? What types of vision defects does it cause? Which type of lens is needed to correct presbyopia?
4. Why do stars twinkle?
5. Explain why sun is visible to us about 2 minutes before the actual sunrise and about 2 minutes after the actual sunset.

5 Mark Questions

1. Give reason for the following:
 - a. We cannot see our surrounding clearly for some time, when we enter a darkened cinema hall from bright sunshine.
 - b. Normal eye not able to see clearly objects placed closer than 25 cm.
 - c. 'Danger' or 'Stop' signal lights red in colour.
 - d. Star seems higher in the sky than they actually are.
 - e. Sun appear red at sunrise.
2. A 14-year old student is not able to clearly see the question written on the blackboard placed at a distance of 5m from him.
 - a. Name the defect he is suffering from. Draw ray diagram showing the defect.
 - b. Write its causes.
 - c. Draw the ray diagram to show how this defect can be corrected.
3. What is long-sightedness? Show the defect with a ray diagram. List two causes for this defect. Draw ray diagram to show how this defect can be corrected.

Electricity

1 Mark Questions

1. Define one ampere.
2. What makes charge to flow?
3. Which of the two has a high internal resistance- Voltmeter or ammeter?
4. Which of these two electric circuits has no flow of electric current- Open circuit or closed circuit?
5. How does the resistance of a conductor vary with its length and area of cross section?
6. Two resistance of 1Ω , each connected in parallel, form a series combination with 1Ω resistance. The ends of this combination are connected to a 12V supply through a key. Draw the circuit diagram too show the combination.
7. What is resistivity?
8. A wire of uniform area of cross section is stretched to four times its original length. By what factor does its resistivity change?
9. How is voltmeter connected in the circuit to measure the potential difference?
10. A heater joined in parallel with a 60W bulb is connected to the mains. If the 60 W bulb is replaced by a 100 W bulb, will the rate of heat produced by the heater be more or less or remains the same?
11. A toaster produces more heat than a light bulb when connected in parallel to the 220 V mains. Which of the two has greater resistance?
12. How many joules are there in 1 kWh?

13. Two bulbs whose resistance is in the ratio 1:2 are connected in parallel to a source of constant voltage. What will be the ratio of power dissipation of these?
14. Two wires A and B are of same metal, have the same area of cross section and have their lengths in the ratio of 2:1. What will be the ratio of currents flowing through them respectively when the same potential difference is applied across length of each of them?
15. A student obtains resistances of 3, 4, 12 and 16Ω using only two metallic resistance wires either separately or joined together. What is the value of resistance of each of these wires?
16. Why is an ammeter likely to be burnt out if you connect it in parallel?
17. When three equal resistors $R\Omega$ are placed in (i) parallel (ii) series, what is the equivalent resistance?
18. When a constant current is applied for a time of t seconds, how can you increase the heat produced to four times?
19. What are the factors on which the heat produced by an electric current depends?
20. Give one practical example of connecting electric bulbs in series combination.

2 Mark Questions

1. Write two disadvantages of connecting electric devices in series.
2. What is Joules's law of heating? Express it mathematically.
3. What is an electric fuse? What is its use?
4. A set of 'n' identical resistors, each of resistance R ohm when connected in series have an effective resistance 'X' ohm, and when connected in parallel, their effective resistance is 'Y' ohm. Find the relation between R , X and Y.
5. What is the conventional direction of the flow of electric current? How does it differ from the direction of flow of electrons?

3 Mark Questions

1. Explain with diagram, what is meant by series combination of resistors. Derive the expression for equivalent resistance when two resistors are connected in series.
2. Explain with diagram, what is meant by parallel combination of resistors. Derive the expression for equivalent resistance when two resistors are connected in parallel.

Numerical

1. A metallic wire of length 1 m is stretched to double its length. Calculate the ratio of its initial and final resistance assuming that there is no change in its density on stretching.
2. A copper wire has a diameter of 0.5 mm and resistivity of 1.6Ω cm. How much of this wire would be necessary to make a 10Ω coil?
3. Calculate the equivalent resistance of the resistance network between the points A and B as shown in the figure when the switch S is closed.

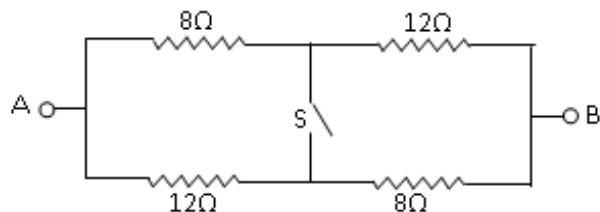

4. Two wires of same material having lengths in the ratio 1:2 and diameters in the ratio 2:3 are joined in series with a battery; calculate the ratio of potential difference across the two wires.

5. A circuit having two electric bulbs of internal resistances 20Ω and 30Ω is connected in a series across a battery of unknown value. If a current of $2A$ is flowing in the circuit, find the voltage of the battery.

6. Calculate the resultant resistance across X and Y in the given circuit and find the total current flowing in the circuit.

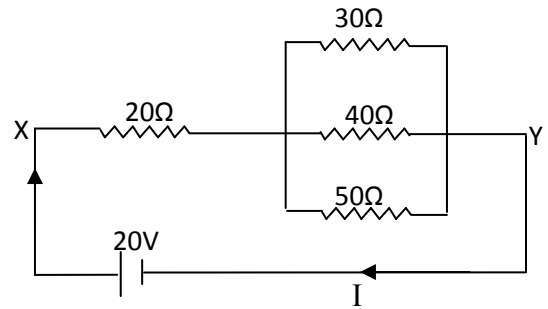

7. A wire of resistance 5Ω is bent in the form of a closed circle. What is the effective resistance between the two points at the ends of any diameter of the circle?

8. Two identical resistors, each of 10Ω , are connected in (i) series and (ii) in parallel, in turn, to a battery of $6V$. Calculate the ratio of power consumed in the combination of resistances in the two cases.

9. A electric iron has a rating of $1000W$, $220V$. When in use calculate (i) the current passing through it, (ii) its resistance and (iii) energy consumed by it in 15 minutes.

10. A wire bent in the form of a circle has resistance of 40Ω . A and B are the two points on the wire dividing it into a quadrant. Find the values of I_1 and I_2 .

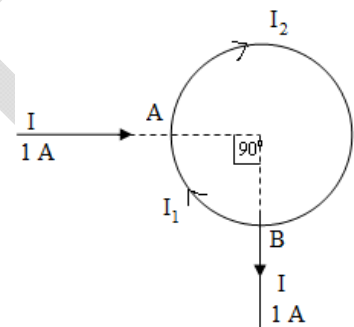

11. Two electric lamps rated $100W$, $220V$ and $25W$, $22V$ are connected in parallel to a $200V$ supply. Calculate the total electric current in the circuit.

12. Two resistance 20Ω and 40Ω are connected in series to a battery of potential difference $10V$. Compare the ratio of the heat produced in 1 minute in the two resistances.

13. A torch bulb is rated $2.5V$ and $750mA$. Calculate (i) its power, (ii) its resistance and (iii) the energy consumed if this bulb is lighted for 4 hrs.

14. A cylinder of a material is 10 cm long and has a cross section of 2 cm^2 . If its resistance along the length is 20Ω , what will be the value of its resistivity in number and units?

15. A resistor of 4Ω resistance and an electric bulb of 20Ω are connected in series across a $6V$ battery. Draw the circuit for this combination. Find the current flowing through the circuit and the potential difference across the electric bulb.

Magnetic effect of electric current

1 Mark Questions

1. The north pointer of a compass points away from one pole of a magnet. Identify the pole of the magnet.
2. Who discovered the fact that electricity and magnetism are interlinked?
3. What does the degree of closeness of the field lines signify?
4. In a coil of wire, current flows in anticlockwise direction. Which magnetic pole will be represented by the front face of the coil?

5. What is the shape of a current carrying conductor whose magnetic field resembles that of a bar magnet?
6. Which rule tells us about the direction of force experienced by a current-carrying conductor in a magnetic field?
7. A negatively charged particle moving downward enters at right angle to a magnetic field acting from right to left. What will be the direction of its deflection?
8. Name the device which converts:
 - a. Electrical energy into mechanical energy.
 - b. Mechanical energy to electrical energy.
9. A positively charged particle is moving in +ve X-direction. Determine the direction of magnetic field which deflects it toward +ve Y-direction.
10. Show wave form of alternate current.
11. What is the main purpose of earthing in an electric appliance?
12. What will be the frequency of an alternating current if its direction changes after every 0.01s?
13. When does electric short circuit occurs?
14. Explain why, a copper wire cannot be used for as a fuse wire?
15. How is the fuse connected in the circuit?

2 Mark Questions

1. Differentiate between direct current and Alternating current.
2. State advantages of AC over DC.
3. Is electromagnet a permanent magnet? Why?
4. Write the principle of :
 - a. Electric motor.
 - b. Electric generator.
5. Draw the magnetic field pattern produced by a current carrying straight conductor. State the factors on which its magnetic field depends.
6. How will you determine the direction of a magnetic field around a current carrying straight conductor?
7. What is solenoid? Describe it briefly.
8. What is electromagnet? State two use of electromagnet.
9. An electric appliance is rated 920W on the 220V mains. What fuse should be fitted in the plug?
10. What precaution should be taken to avoid the overloading of domestic electric circuits?

3 Mark Questions

1. Draw a schematic labeled diagram of a domestic wiring circuit and describe it briefly.
2. Describe an activity to show that the current is induced in a coil when the current in a nearby coil is changed.
3. Describe an activity to show the pattern of magnetic field of a straight current carrying conductor.

Sources of energy

2 Mark Questions

1. What are the qualities of ideal source of energy?
2. What is good fuel?
3. Why, for a person living in a remote village, cow dung cake is better fuel than LPG for cooking food?
4. Explain the working of Gobar gas plant.
5. Sun is the ultimate source of energy. Explain.
6. What steps would you suggest to reduce energy consumption?
7. State two advantages of using wind energy for generating electricity.
8. Explain electricity generation mechanism of a thermal power plant.
9. Differentiate between renewable and non-renewable sources of energy.
10. Describe the construction of solar cooker.

GIRISH